

# TAB8

INFINITELY MOBILE



[www.rmupos.co.uk](http://www.rmupos.co.uk)

8" Screen LED 1280 X 800  
PCAP Panel  
E-money compatible  
Camera  
Bluetooth  
**Wireless**  
IP65



# CONFIGURATIONS



TAB8



Black

## TAB8

Screen	8"
Touch Panel	Multi-Touch (PCAP)
Brightness	500 nits
Resolution	1280 x 800
Dust & water Proof	IP65
Fall Security	1.2m drop
Camera	5MP
Sensor	G-sensor, Ambient light sensor, Hall sensor, Gyro
LED indicator	1
Vibrator	Vibrator motor
Wireless LAN + Bluetooth	802.11 a/b/g/n/ac, 2.4G/5GHz, BT4.0+LE

## MODEL

### TAB8

Processor	Intel Cherry Trail Quad Core
Memory / Storage	4GB LPDDR3 / 64GB eMMC
Expansion	1 x Mini Slot-E Slot
Graphic Engine	Intel HD Graphic
Battery	7454mAh, 3.85V, Battery life up to 8hrs
Power Adapter	36W / 12V

## INPU/OUTPUT

Micro SD Socket	1
USB 3.0	1 Type C
Audio Jack	1
DC Jack	1 x 2 pin
Audio speaker	1 x 1W
POGO I/O Port	USB/Power

## OS COMPATABILITY

Win 10 IOT ENTRY (64 bit) & Android

## VARIOUS

Dimensions W x D x H	228 x 16.5 x 146mm
Weight	600g
Colour	Black
Setup	Horizontal from 0° to 90°
Certifications	FCC/CE Class A, LVD, CE Mark
Operating temperature	0°C ~ 40°C
Storage temperature	-10°C ~45°C
Humidity	20% ~ 80% without condensation

## PACKAGING

Unit	1
Dimensions l x L x H	400 x 500 x 340mm
Weight	830g

## OPTIONS

- Cradle (5 slots)
- 3-Track MSR (USB)
- SCAN 2D
- Fingerprint
- Support TPE (M-case 103-02) compatible: Ingenico iCMP
- Support TPE (M-case 103-05) compatible: Verifone E355 & Miura M010
- Support TPE ID TECH VP3300

www.rmshpos.co.uk

## OPTIONS

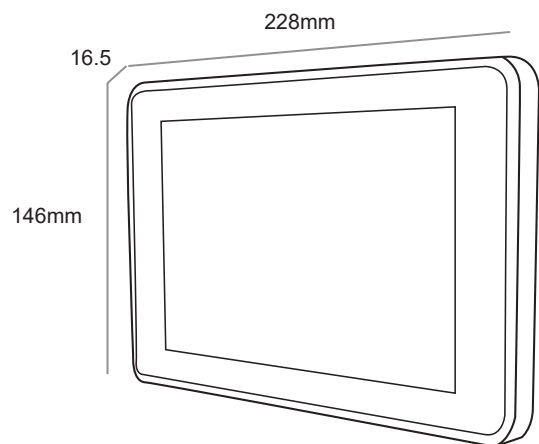

Specifications are subject to change without notice. © OXHO 2019